



**PEMBINA
CONCRETE**
PRODUCTS LTD.



**Where Structure Meets STRENGTH:
The Best Tanks on the Market**



For over 25 years, Pembina Concrete Products Ltd., has been manufacturing top quality precast concrete tanks. Established in 1989, Pembina Concrete Ltd., is a family run business that commitment to its customers ensures products and service are second to none.

Our core group of employees make it a daily priority to manufacture tanks safely while ensuring that our quality control guidelines are met for every product that leaves the shop. With a state of the art production and loading facility we strive to get our products to your site with zero delays. These are the business practices that have built our company and will continue to ensure our company grows and changes with the needs of our customers and Alberta's ever changing economy.



TABLE OF CONTENTS

CONTENTS.....	PAGE
CSA Specs.....	1
Septic Tanks.....	1
Holding Tanks.....	4
Installation.....	4
Warranty.....	5
Pembina Concrete Products.....	5
London Boulder.....	6
Sumps and Parking Curbs.....	7
Plumbing Supplies.....	8
Sponsorship.....	9



Our CSA certified septic and sewage holding tanks are tested for a burial of up to 3m. PCP tanks are constructed with 40 MPA - Type 50 concrete, as well as steel reinforcement to ensure strength and integrity.

Our unique dome shaped tanks are the largest one piece tanks of their kind, which means no stacking or piecing together on the job site.



WC 740R

- This tank is designed for a 2-3 bedroom home.
- 2- 24" entry man ways
- Working capacity - 740 gallons
- Dosing compartment - 373 gallons
- Burial 3m

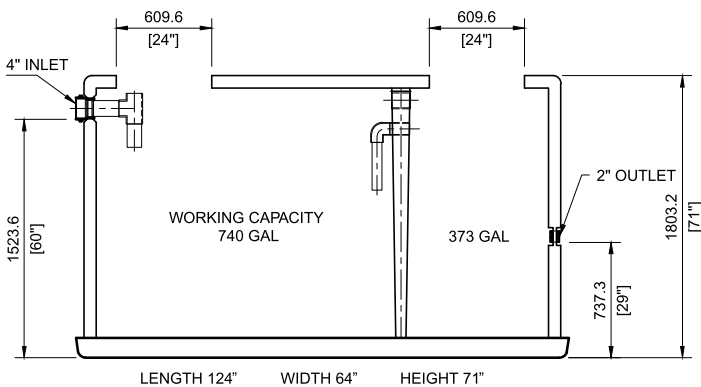

WC 780LP

- This low profile tank is suitable for a large 2-3 bedroom home.
- 2-24" entry man ways
- Working capacity - 780 gallons
- Dosing compartment - 430 gallons
- Burial 3.5m

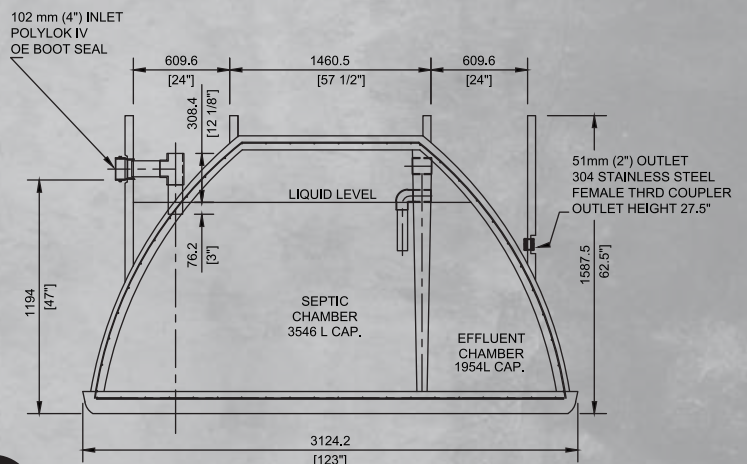

SEPTIC TANKS

WC 940

- This mid range tank is suitable for most 4 bedroom homes.
- 2-24" entry man ways
- Working capacity - 940 gallons
- Dosing compartment - 430 gallons
- Burial 3M

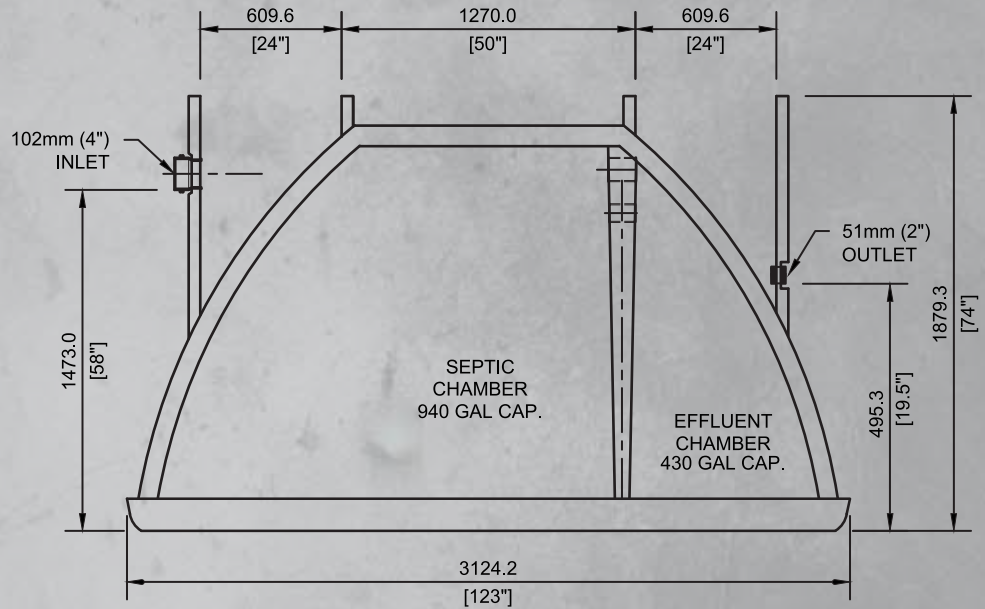

WC 1150

- This large septic tank is suitable for most 5 bedroom homes.
- 2-24" entry man ways
- Working capacity - 1150 gallons
- Dosing compartment - 506 gallons
- Burial 3M

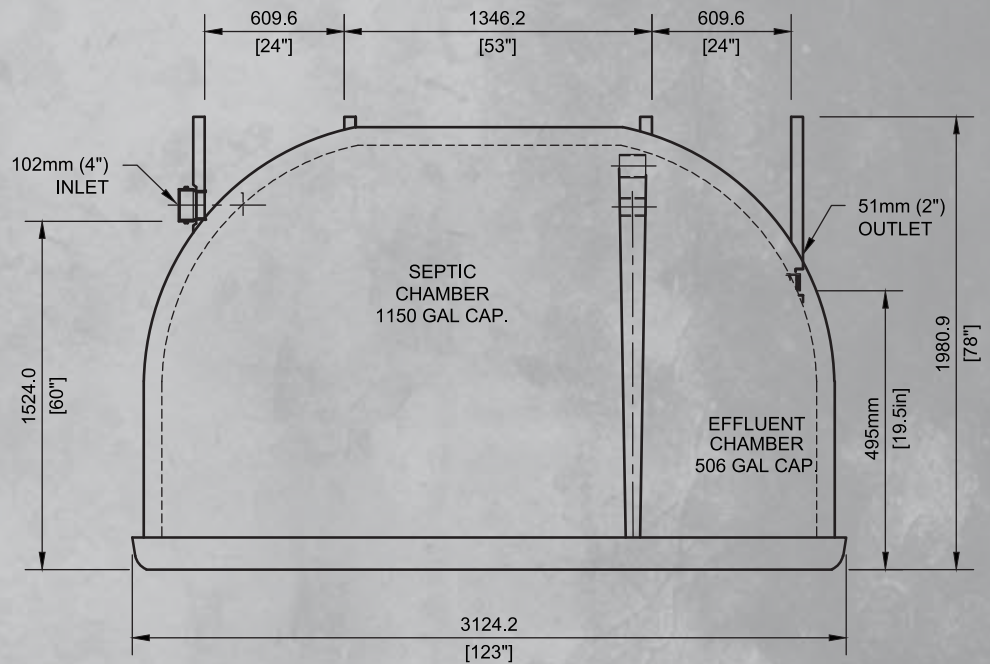

SEPTIC TANKS

WC 1600

- This tank is our largest septic tank. It is suitable for 6 bedroom plus homes.
- Working capacity - 1600 gallons
- Dosing compartment - 650 gallons
- Burial 3M

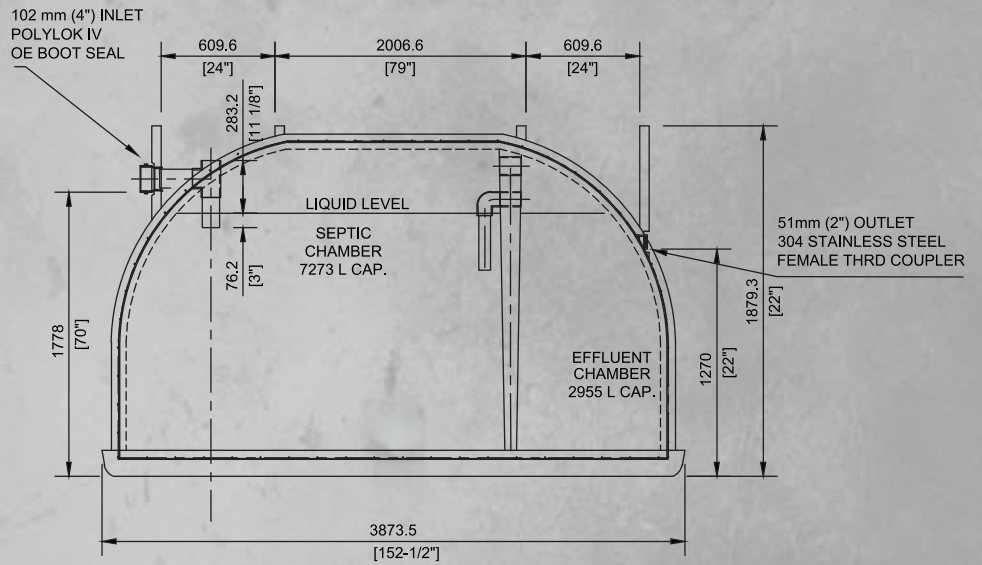

2000 Low Profile

“Coming spring 2025”

- 2300 gallons low profile holding tank.
- With an inlet of 54” this low profile tank will meet your shallow burial needs.



HOLDING TANKS AND CISTERNS

Pembina Concrete Products Ltd., holding tanks and fresh water cisterns are available in many sizes. 500 gallons , 750 gallons, 1200 gallons, 2000 gallons, 2800 gallons, and 3200 gallons.

All of our holding tanks and cisterns are one piece to eliminate any leak points. Cisterns all come with a 1 1/4" brass discharge fitting for easy hook up as well as a vent and fill assembly in the lid.

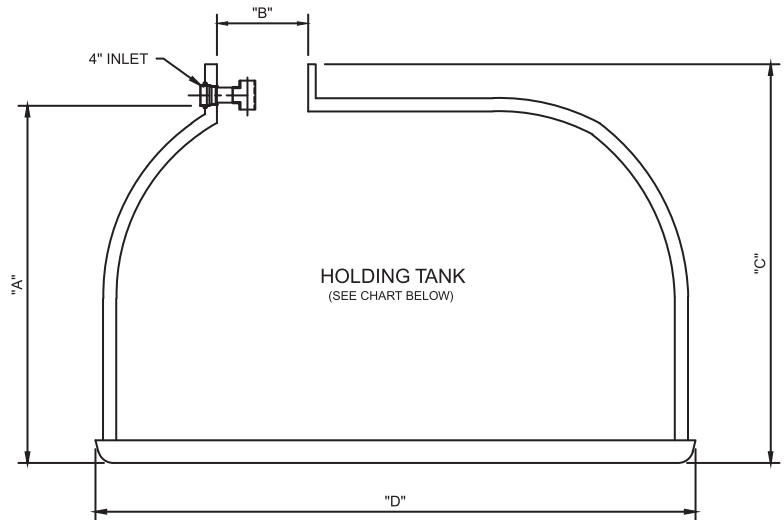

HOLDING TANK DIMENSION CHART								
HT/ WHT	A	B	C	D	WIDTH	VOL (gal)	WGT (lbs)	WHT Outlet
500	58"	24"	79"	73"	53"	500	6,500	-
1200	66"	24"	76"	102"	78"	1200	10,000	1-1/4"
2000	74"	24"	84"	126"	102"	2000	13,000	BRASS
2800	84 1/2"	24"	92"	146"	108"	2800	17,000	Coupler
3200	88"	24"	99"	147"	110"	3200	20,000	

INSTALLATION

Installation Requirements for warranty qualification

- Dig a hole a minimum of one foot larger than the tank. Tank MUST be placed on perfectly solid and level ground. (Hole must not be high in the center) Use 1" washed rock or gravel for leveling to help sit flat without voids or high spots. Solid footing around the perimeter to help sit flat without voids on high spots. The inlet side of the tank should be as close to the inlet trench as possible.
- Tank must not be filled with water until it is completely backfilled.
- Keep tires or tracks 2 feet back from tank when backfilling.
- Tanks should be backfilled all around, evenly, in 2 foot intervals.
- Do not apply any pressure to the lid or to the 6" ABS pipe.
- Finish by mounding dirt over tank. Water will run off and dirt will settle.
- There must be not equipment or vehicle traffic allowed within 2 feet of the edge of tank at all times.
- Leave a minimum of 1 ft of water in any cistern or sewage holding tank that will be left unused, especially over the winter months.
- Warranty will not be honored if tank is not properly installed.



WARRANTY POLICY

- Pembina Concrete Products Ltd., offers a 20 year prorated warranty on tanks installed to your specifications.
- Warranty covers 100% replacement or repair cost if tank is proven to be defective within two years of installation.
- Warranty after two years will be prorated at 10% yearly, on cost of the tank only.
- Warranty applies to original owner and or original installation.
- Costs of repair or replacement will require prior approval by Pembina Concrete Products Ltd., to be considered for warranty coverage.
- This warranty does not cover the replacement of any materials lost due to leakage or cost of damages resulting from leakage.
- Pembina Concrete Products Ltd., will not warranty any tanks damaged due to improper installation or usage.

PEMBINA CONCRETE PRODUCTS

Delivery

Our fleet of tri-drive rear mounted knuckle pickers can deliver products wherever your next job takes you. Our experienced drivers are the best in the business and can get your tank set no matter what the conditions.

Pick up

If you have the equipment to pick up your own tank, we have a state of the art loading facility that allows you to drive in and out with minimal wait time.



Inventory

Pembina Concrete Products Ltd., is situated on 60 acres that allows us to keep many tanks of all models in stock and ready at a moments notice.

LONDON BOULDER

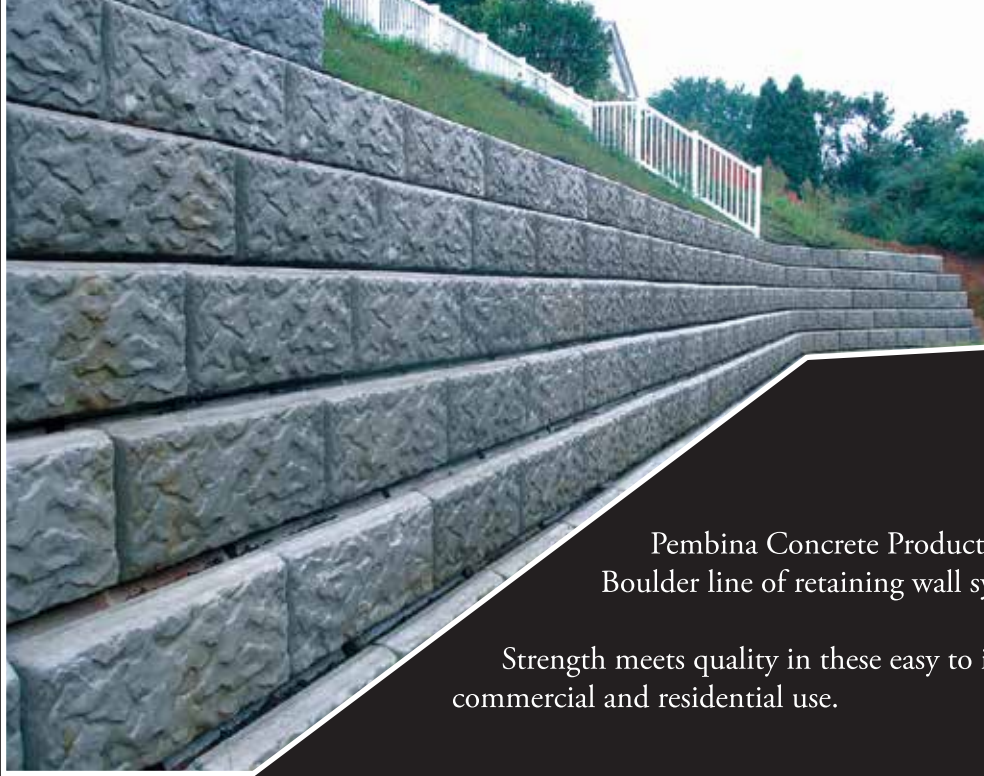

Pembina Concrete Products Ltd., is pleased to supply the London Boulder line of retaining wall systems.

Strength meets quality in these easy to install blocks that can be used for both commercial and residential use.

LB42™

- 42" deep blocks
- Multiple setbacks
- Multiple face textures
- Dual face walls
- Free standing wall

LB42 - 42" Full Boulder

Dimensions: 48" x 18" x 42"
 Weight: 2160 lbs.
 Sq. Ft. / Block: 6 sq. ft.



LB42 - Cap Boulder

Dimensions: 48" x 18" x 38"
 Weight: 1260 lbs.
 Sq. Ft. / Block: 6 sq. ft.



LB42 - Right Cap Corner

Dimensions: 24" x 18" x 34"
 Weight: 660 lbs.
 Sq. Ft. / Block: 3 sq. ft.



LB42 - Left Cap Corner

Dimensions: 24" x 18" x 34"
 Weight: 660 lbs.
 Sq. Ft. / Block: 3 sq. ft.



LB42 - 90 Degree Return

Dimensions: 48" x 18" x 24"
 Weight: 1250 lbs.
 Sq. Ft. / Block: 9 sq. ft.



Pembina Concrete Products Ltd., offers one and two - compartment garage/shop sumps. Complete with a solid lid, and or grate. They are easily installed to complete your garage or shop floor.

2 Compartment dimensions:

- 60" long
- 31" wide
- 39 3/4" tall

1 Compartment Dimensions:

- 30" long 31" wide
- 39 3/4" tall



Parking curbs

Dimensions 8' long 7" wide 6" high

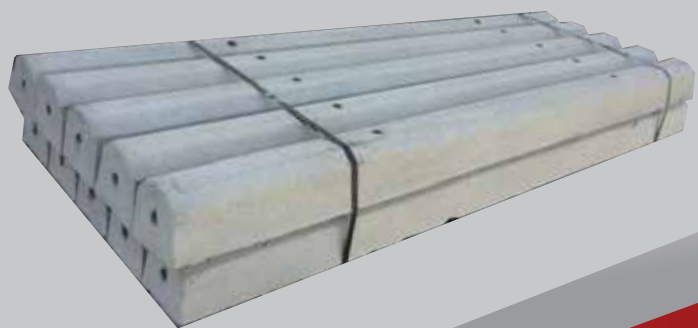

PLUMBING SUPPLIES



Quick4 Plus Standard Low Profile

Chambers are 8" high and can be installed in 36" wide trenches.



Quick5 Standard

Chambers are 12" in height and can be installed in 36" wide trenches.

Pembina Concrete Products Ltd., maintains a comprehensive inventory of septic tanks, components, and materials for field installations. In addition, we are a distributor of the following products:



SPONSORSHIP



Pembina Concrete Products Ltd., is more than just a business; we're an integral part of the community we serve. We're dedicated to giving back, and we're delighted to sponsor a wide array of local organizations.

Our support extends to enriching educational opportunities in our schools, celebrating the thrill of hockey and rodeo, and preserving the agricultural heritage of our area through our recreation society. We recognize the importance of these groups and are committed to their continued success.



NOTES:



 Box 123, Entwistle, Alberta T0E 0S0

 780-727-2702

1-800-661-3047

 pemcon@telus.net

 www.pembinaconcrete.com

